



# Solenoid valve 2/2 way N.C. With pilot control

21W3KB190  
÷  
21W7KB500

## PRESENTATION:

S.V. with pilot control for interception of fluids compatible with the construction materials.

A minimum operational pressure of 0,2 bar is required.

The materials used and the tests carried out ensure maximum reliability and duration.

**USE:** Automation  
Heating

**PIPES:** G 3/4 - G 2

**COILS:** 8W - Ø 13  
BDA - BDS - BSA 155°C (class F)  
BDP 160°C (high mperature)  
BDF - BDV 180°C (class H)

**MOULDING AND BOBBIN ARE MADE BY 100% VIRGIN MATERIAL.**

Max. allowable pressure (PS)

G 3/4 - G 1 25 bar  
G 1 1/4 - G 2 16 bar

Environment temperature:

with coil class **F** or high temperature - 10°C + 60°C  
with coil class **H** - 10°C + 80°C



Gaskets	Temperature		Medium
<b>B</b> =NBR (nitrile rubber)	- 10°C	+ 90°C	Air, inert gas, water
<b>E</b> =EPDM (ethylene-propylene)	- 10°C	+140°C	Water, low pressure steam
<b>V</b> =FKM (fluoroelastomer)	- 10°C	+140°C	Mineral oils (2°E), gasoline gas oil

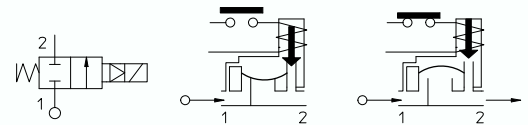

For seals other than NBR replace the letter "B" with the ones corresponding to the other seals. E.I. 21W3KE190.

Pipe ISO 228/1	Code	Max viscosity		Ø mm	Kv l/mn	Power (watt)	Pressure		
		cSt	°E				min bar	M.O.P.D. AC bar DC bar	
G 3/4	21W3KB190	12	~ 2	19	140	8	0,2	16	16
G 1	21W4KB250			25	190				
G 1 1/4	21W5KB350			35	400			10	10
G 1 1/2	21W6KB400			40	520				
G 2	21W7KB500			50	750				



**CE Approval**

(Pressure Equipment Directive 97/23/CE)

for EV 21W5÷21W7

The "ODE" reserves the right to carry out technical and aesthetic modifications without prior

### MATERIALS:

<b>Body</b>	Brass - UNI EN 12165 CW617N
<b>Armature tube</b>	Stainless steel AISI series 300
<b>Fixed core</b>	Stainless steel AISI series 400
<b>Plunger</b>	Stainless steel AISI series 400
<b>Phase displacement ring</b>	Copper - Cu 99,9%
<b>Spring</b>	Stainless steel AISI series 300
<b>Seal</b>	Standard: B=NBR On request: E=EPDM V=FKM
<b>Orifice</b>	Brass - UNI EN 12165 CW617N

<b>On request:</b>	Pg 9 or Pg 11
<b>Connector</b>	ISO 4400
<b>Connector conformity</b>	

### FEATURES:

<b>Electrical conformity</b>	IEC 335
<b>Protection degree</b>	IP 65 EN 60529 (DIN 40050) with coil fitted by connector.

### SPARE PARTS:

<b>1. Coil:</b>	See coils list	<b>KIT:</b>	KT130KB30-A=2+3
<b>2. Complete plunger:</b>	Code R450886/B	<b>MAINTENANCE KIT:</b>	
<b>3. Complete armature tube:</b>	Code R450606	G 3/4-G 1	KTG0W3KB19=2+4+5
<b>4. Gasket O-Ring:</b>	G 3/4-G 1 Code R990002/B	G 1 1/4-G 1 1/2	KTG0W5KB35=2+4+5
	G 1 1/4-G 1 1/2 Code R990005/B	G 2	KTG0W7KB50=2+4+5
	G 2 Code R990081/B		
<b>5. Complete diaphragm:</b>	G 3/4-G 1 Code R450431/B		
	G 1 1/4-G 1 1/2 Code R450466/B		
	G 2 Code R450432/B		

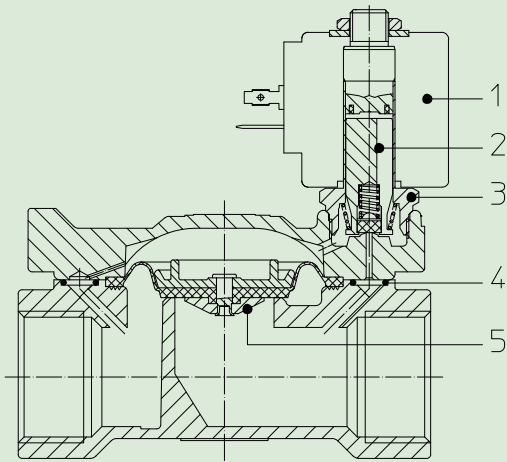

### DIMENSIONS:

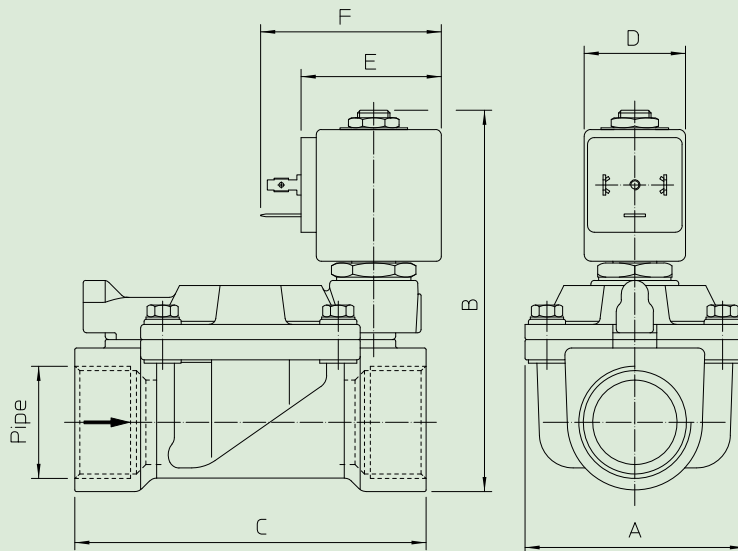

Type	Pipe ISO 228/1	A mm	B mm	C mm
21W3KB190	G 3/4	65	105	104
21W4KB250	G 1		112	
21W5KB350	G 1 1/4	98	125	144
21W6KB400	G 1 1/4			
21W7KB500	G 2	118	141	172

COIL W ---	POWER ABSORPTION		TYPE	DIMENSIONS		
	Inrush VA ~	Hold VA ~		D mm	E mm	F mm
8 W	25	14,5	B	30	42	54